

CHARGRILL SERIE 600 CABINET 800 2016

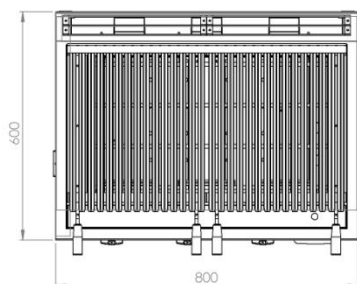
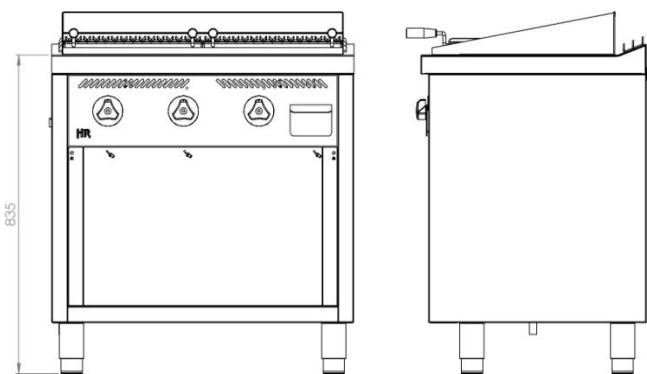

GENERAL FEATURES

Brand	FAINCA HR
Family	CHARGRILL
Model	B6008E
Main color	Stainless Steel
Secondary color	NO
Control devices	YES
Control type	KNOB
Type of heating	GAS
Selecting the degree of temperature	2 positions - Adjustable
Useful area (cm2)	3045
Removable grills	YES
Adjustable height grill	YES
Volcanic rock	YES
Cleaning	Stainless Steel.
Body material	Stainless Steel.
Heat resistant housing	YES
Grease trays	2

PACKAGE DETAILS

EAN Code	8437006791335
Standard pcs per packing unit / carton	1
Net weight (kg)	78
Gross weight (kg)	88
Standard pcs per pallet	1

TECHNICAL DATA

Certifications of approval	CE
Maximum Gas power (kW)	19,5
Number of burners	3
Power per burner (kW)	6,5
Safety device	YES - THERMOCOUPLE
Ignition light	NO
Piezoelectric	NO

DIMENSIONS OF THE APPLIANCE

Device dimensions (height, width, depth) (mm)	947x800x600
Measures of the product packed (mm)	1050x880x680